

# Coin Recycling System



- Turnkey Solution with USB Connection
- Space Efficient Design
- Coin Recycling
- World Currency Solution
- Built on Proven Technology
- Bulk Coin Input
- High Capacity

The compact design of the CR100 offers space efficient, integrated coin recycling; accepting customers' coins in bulk, sorting to individual coin hoppers and providing change at the end of a transaction. With a minimum coin-in to coin-out height, the CR100 is ADA and DDA compliant and is available for world coins.



# Coin Recycling System



## Key Features

- Turnkey solution with USB interface connection
- Space efficient design
- World currency solution
- Built on proven technology
- Bulk coin in, up to 50 coins
- High capacity e.g 2300 x US \$0.01 coins<sup>\*1</sup>
- Flexible hopper positioning with automatic value and identification
- Remote download of coins/firmware
- Multi-coin accept at up to 2 coins per second and flexible sorting
- Debris management
- Rapid 8 coins per second payout
- Programmable to accept and sort up to 16 coins
- Auto-refill option provides full coin data reconciliation
- Auto jam detection and clearance
- Six, five and four hopper options with standard and double bowls
- Minimum coin-in to coin-out height - ADA and DDA compliant
- Integrated mounting runners / slides with locking option

## High Capacity

The Compact Hoppers can be configured in two sizes, standard and double, their high capacity offers longer run times maximising the time between refills. With automatic position and value identification, the hoppers can be placed in any location and the CR100 will automatically adjust accordingly.

## Compact Design

The innovative design of the CR100 minimises coin in to coin out height and provides a very compact space envelope while maintaining high coin hopper capacity. Coin input and output cups are ergonomically and prominently positioned allowing the CR100 to be easily integrated into kiosk or ticket enclosures. Ideal for mounting under counter or at table top height, the CR100 offers maximised coin capacity in a minimised space envelope.

## Reliability

The CR100 utilises proven coin transport modules and components to deliver a highly reliable coin recycling system which is based on over 40 years of currency handling expertise. Auto jam detection and clearance functions means the CR100 can cope with most issues without the need for manual attendance.

## Product Integration

Money Controls' focus on application engineering ensures that integrating the CR100 into an OEM cabinet is straightforward. A single USB connection provides easy software integration based on a simple API.

## Security

Detailed audit data provides comprehensive records of coins in and out. Accurate coin validation minimises the risk of accepting fraudulent coins and lock options prevent access to the coin hopper bowls.

## Dimensions

### TOP

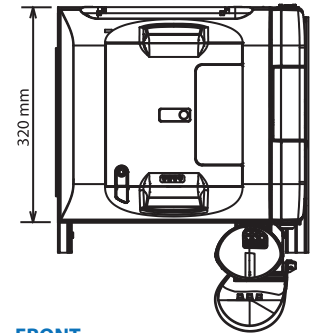

### FRONT

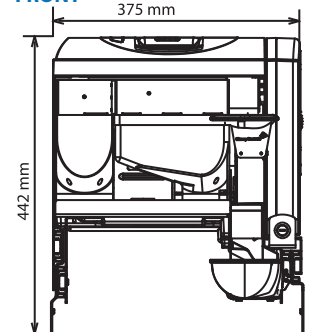

### SIDE

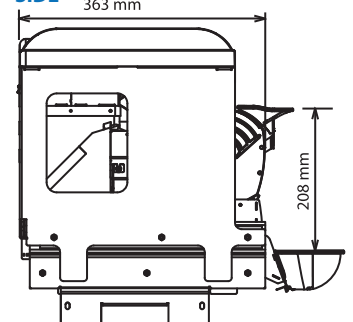

## Technical Data: CR100

### GENERAL

Dimensions mm (HxWxD):	294 x 369 x 320 (excl. mount rails & coin cups) 442 x 375 x 363 (inc. mount rails & coin cups)
Currencies:	All world currencies
Validation Speed:	Up to 2 coins per second
Operating Conditions:	0° C to 55° C
Power Supply:	24V DC, 6A (Peak)
MCBF (User Recoverable)	1 in 150,000 coins
(Service Call)	1 in 300,000 coins
EoML	2,000,000 coins

E&OE <sup>\*1</sup> Coins filled manually in to a double bowl hopper



CRANE PAYMENT INNOVATIONS